

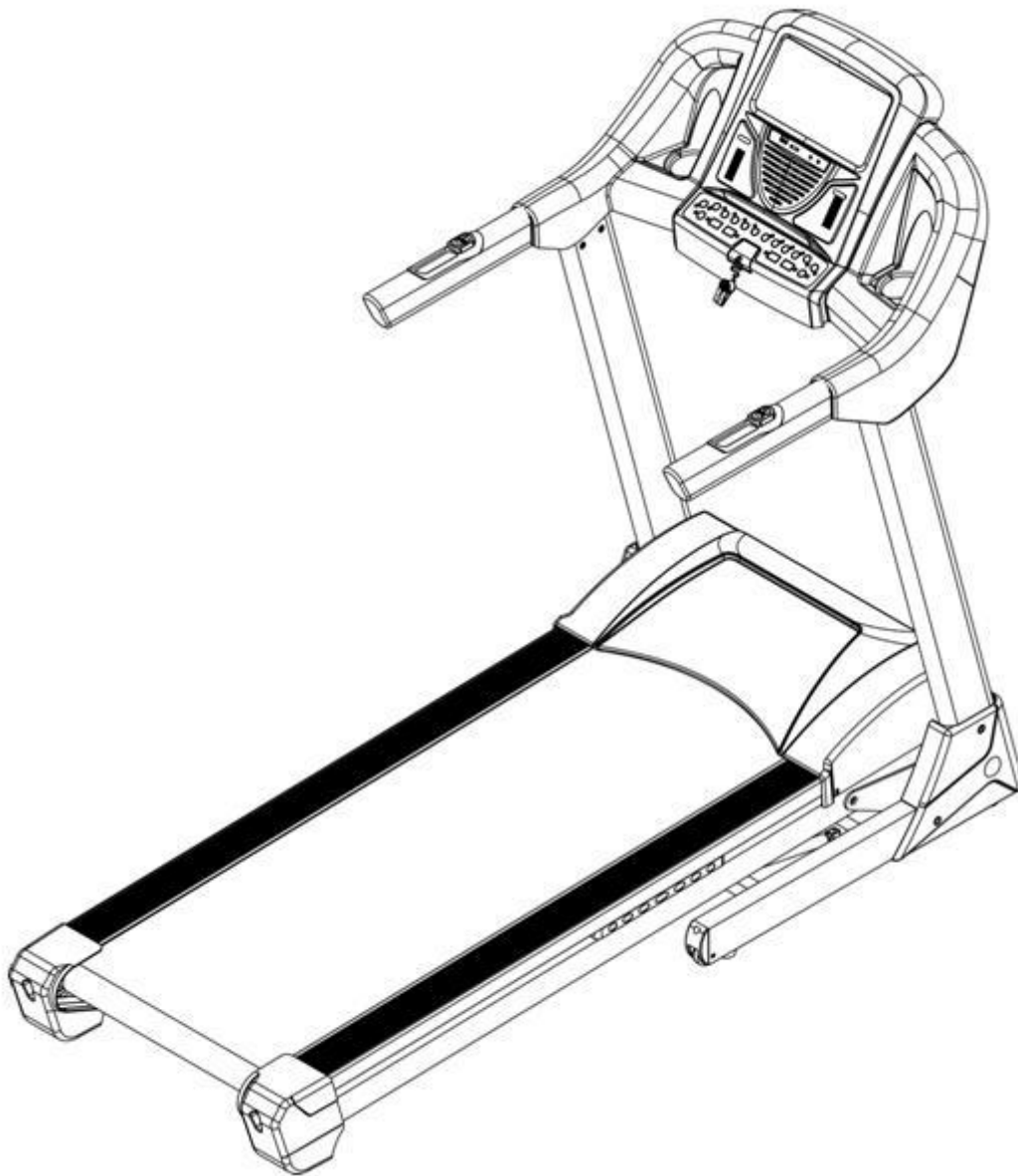

GOLD OWNER'S MANUAL



Product may vary slightly from the item pictured due to model upgrades.

Read all instructions carefully before using this product. Retain this owner's manual for future reference.

TABLE OF CONTENTS

1.	IMPORTANT SAFETY INSTRUCTIONS	3
2.	IMPORTANT ELECTRICAL INFORMATION	4
3.	IMPORTANT OPERATING INSTRUCTIONS	5
4.	ASSEMBLY INSTRUCTIONS	6
5.	FOLDING INSTRUCTIONS	10
6.	TECHNICAL PARAMETERS	11
7.	GROUNDING METHODS	12
8.	OPERATION GUIDE	13
9.	EXERCISE GUIDE	22
10.	MAINTENANCE GUIDE	24
11.	EXPLODED DIAGRAM	28
12.	PARTS LIST	29
13.	TROUBLE SHOOTING GUIDE	31
14.	WARRANTY	32

1. IMPORTANT SAFETY INSTRUCTIONS

WARNING - Read all instructions before using this treadmill.

It is important your treadmill receives regular maintenance to prolong its useful life. Failing to regularly maintain your treadmill may void your warranty.

Danger – To reduce the risk of electric shock disconnect your treadmill from the electrical outlet prior to cleaning and/or service work.

DO NOT USE AN EXTENSION CORD: DO NOT ATTEMPT TO DISABLE THE GROUNDED PLUG BY USING IMPROPER ADAPTERS OR IN ANY WAY MODIFY THE CORD SET.

- Install the treadmill on a flat level surface with access to a 220-240 volt (50/60Hz), grounded outlet.
- Do not operate treadmill on deeply padded, plush or shag carpet. Damage to both carpet and treadmill may result.
- Do not block the rear of the treadmill. Provide a minimum of 1 metre clearance between the rear of the treadmill and any fixed object.
- Place your unit on a solid, level surface when in use
- Never allow children on or near the treadmill.
- When running, make sure the plastic clip is fastened on your clothing. It is for your safety, should you fall or move too far back on the treadmill.
- Keep hands away from all moving parts.
- Never operate the treadmill if it has a damaged cord or plug.
- Keep the cord away from heated surfaces.
- Do not operate where aerosol spray products are being used or where oxygen is being administered. Sparks from the motor may ignite a highly gaseous environment.
- Never drop or insert any object into any openings.
- The treadmill is intended for in-home use only and not suitable for long time running.

- To disconnect, turn all controls to the off position, remove the safety key, and then remove the plug from the outlet.
- The pulse sensors are not medical devices. Various factors, including the user's movement, may affect the accuracy of heart rate readings. The pulse sensors are intended only as exercise aids in determining heart rate trends in general.
- Use the handrails provided; they are for your safety.
- Wear proper shoes. High heels, dress shoes, sandals or bare feet are not suitable for use on your treadmill. Quality athletic shoes are recommended to avoid leg fatigue.
- Allowed temperature: 5 to 40 degrees.

Remove the safety key after use to prevent unauthorized treadmill operation.

2. IMPORTANT ELECTRICAL INFORMATION

WARNING!

- NEVER use a ground fault circuit interrupt (GFCI) wall outlet with this treadmill. Route the power cord away from any moving part of the treadmill including the elevation mechanism and transport wheels.
- NEVER remove any cover without first disconnecting AC power.
- NEVER expose this treadmill to rain or moisture. This treadmill is not designed for use outdoors, near a pool, or in any other high humidity environment.

3. IMPORTANT OPERATING INSTRUCTIONS

- Be sure to read the entire manual before operating your machine.
- Understand that changes in speed and incline do not occur immediately. Set your desired speed on the computer console and release the adjustment key. The computer will obey the command gradually.
- Use caution while participating in other activities while walking on your treadmill, such as watching television, reading, etc. These distractions may cause you to lose balance or stray from walking in the centre of the belt; which may result in serious injury.
- In order to prevent losing balance and suffering unexpected injury, **NEVER** mount or dismount the treadmill while the belt is moving. This unit starts with at a very low speed. Simply standing on the belt during slow acceleration is proper after you have learned to operate this machine.
- Always hold on to handrail while making control changes.
- A safety key is provided with this machine. Remove the safety key will stop the walking belt immediately; the treadmill will shut off automatically. Inserting the safety key will reset the display.
- Do not use excessive pressure on console control keys. They are precision set to function properly with little finger pressure.

4. ASSEMBLY INSTRUCTIONS

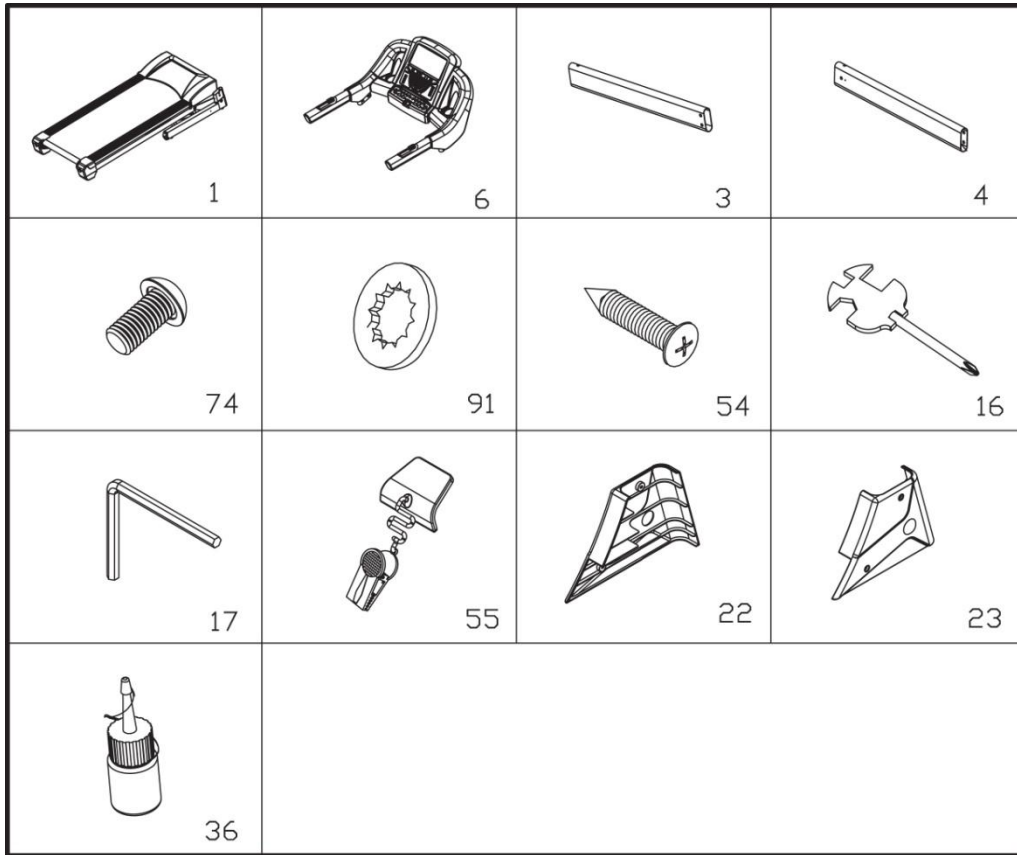

PART LIST

#	Description	Specification	QTY
1	Main frame		1
6	Computer assembly		1
3	Left upright		1
4	Right upright		1
74	Bolt	M10*15	14
91	Washer	10	14
54	Screw	ST4.2*19	4
17	Allen Wrench	6mm	1
16	Allen Wrench	S=13、14、15	1
55	Safety lock		1
22	Left base cover		1
23	Right base cover		1

STEP 1:

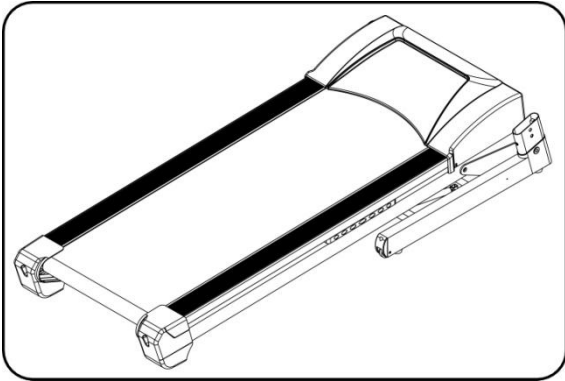

1. Open the carton
2. Extract the parts listed above
3. Place the Main Frame (#1) onto level ground

STEP 2:

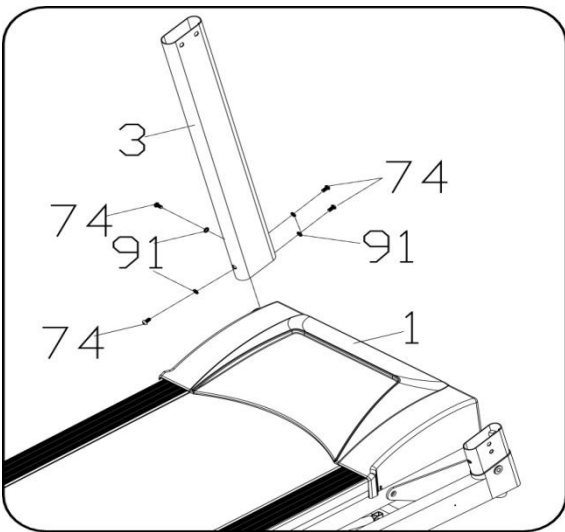

1. Insert left upright (#3) into the left side of base frame set (#1)
2. Use the 6mm Allen wrench (#17), M10*15 bolt (#74) and washer (#91) to lock the left upright (#3) onto the base frame.

STEP 3:

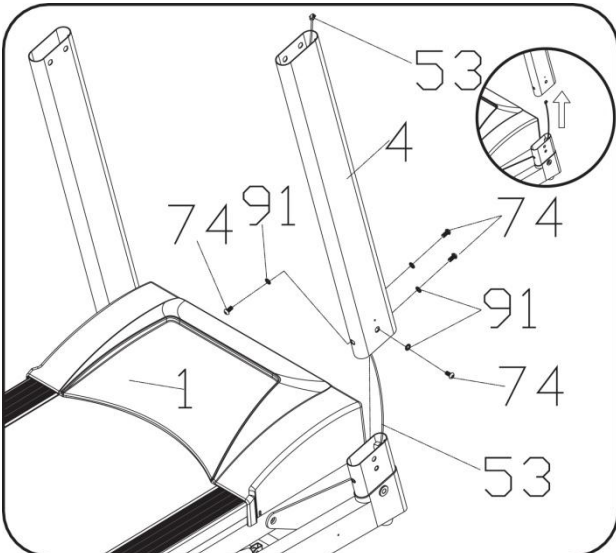

1. Locate the computer bottom wire (#53) inside the right upright (#4).
2. Insert the right upright into the right base of main frame (#1).
3. Fix them onto the base with the 6mm Allen wrench, bolt M10*15 (#74) and lock washer (#91.)

Caution: Take care not to damage the computer wire upon inserting upright tubes into the base frame

STEP 4:

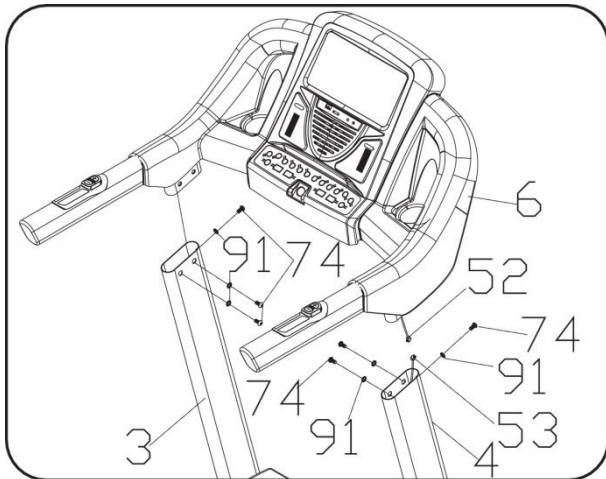

1. Connect the computer bottom wire (#53) to computer up wire (#52)
2. Insert \ computer assembly (#6) into left & right upright (#3) (#4).
3. Use 6mm Allen wrench, M10*15 bolt (#74) and Washer (#91) to secure the computer assembly (#6) onto left and right upright tubes (#3) (#4).

Caution: Take care not to damage the computer wire upon inserting computer into upright tubes

STEP 5:

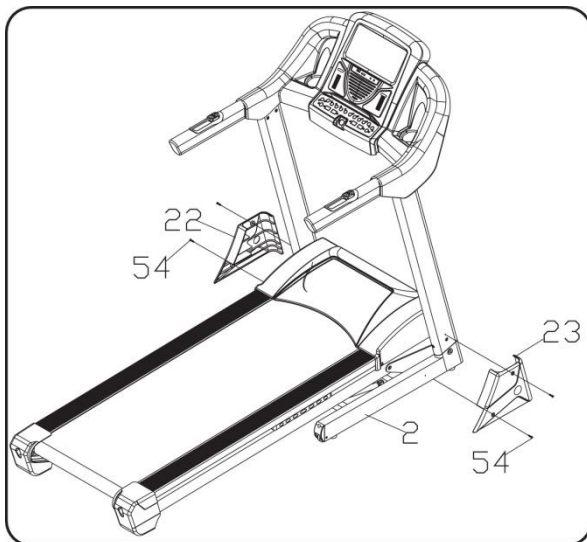

1. Use the 6mm Allen wrench, M10*15 bolt (#74) and washer (#91) to secure the left and right upright tubes to the base frame (#2).
2. Use Allen wrench (#16) and screw (#54) to lock the left and right base cover (#22) (#23) onto base frame.

STEP 6:

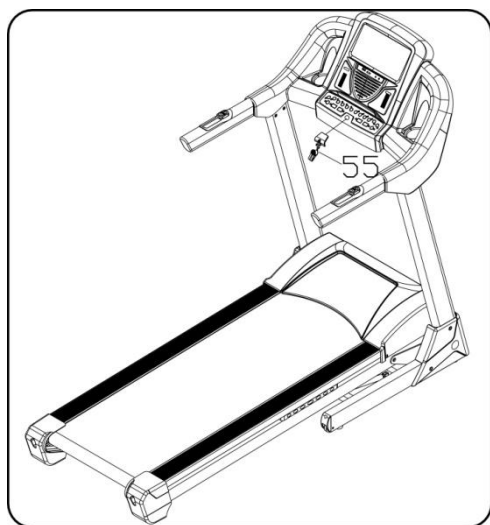

1. After tightening all screws, place the safety key (#55) into position on the computer

5. FOLDING INSTRUCTIONS

Folding:

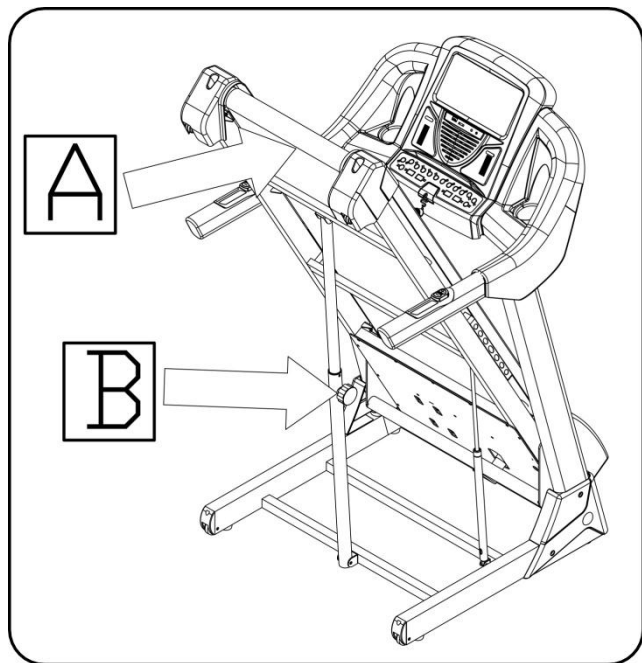

Erect the base frame using position (A) until you hear the click sound emitted when the air pressure bar (B) is locked into the round tube.

Unfolding:

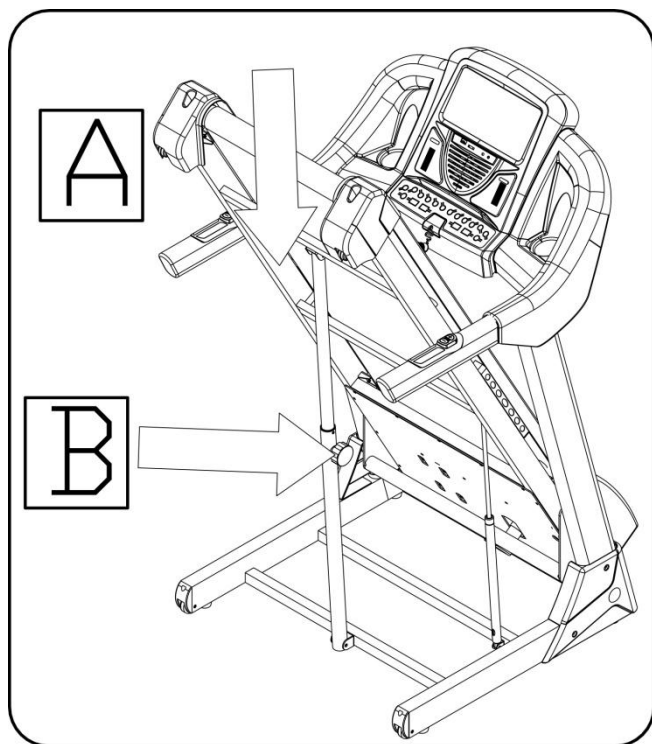

1. Whilst supporting position (A) with your hand, pull out the pin (B) with your right hand.
2. Maintain this pin position whilst gently pulling the base frame towards the ground. Let the base frame descend slowly to the ground.
3. The base frame will descend automatically. (Please keep people and any pets away the machine during descent)

6. TECHNICAL PARAMETERS

Build up size(mm)	1871*1485*860mm	Power supply	As the shown on the nameplate
Foldable size (mm)	1020*860*1740mm	Max. power output	As the shown on the nameplate
Speed range	1.0-22km/h		
Net weight	101KG		
1 blue backlit LCD display	Speed /Time/Distance/ Calories/ Pulse		

7. GROUNDING METHODS

This product must be grounded. In the event of malfunction or breakdown, grounding reduces the risk of electric shock. This product is equipped with a cord with an equipment-grounding conductor and a grounding plug. The plug must be plugged into an appropriate outlet that is properly installed and grounded in accordance with all local codes and ordinances.

DANGER

Improper connection of the equipment-grounding conductor can result in risk of electric shock.

Check with a qualified electrician or serviceman if you are in doubt as to whether the product is properly grounded.

Do not modify the plug provided with the product – if it will not fit the outlet; have a proper outlet installed by a qualified electrician.

This product is for use on a nominal 240-volt circuit and has a grounding plug that looks like the plug illustrated in sketch A in following figure. Ensure the product is connected to an outlet having the same configuration as the plug. No adapter should be used with this product.

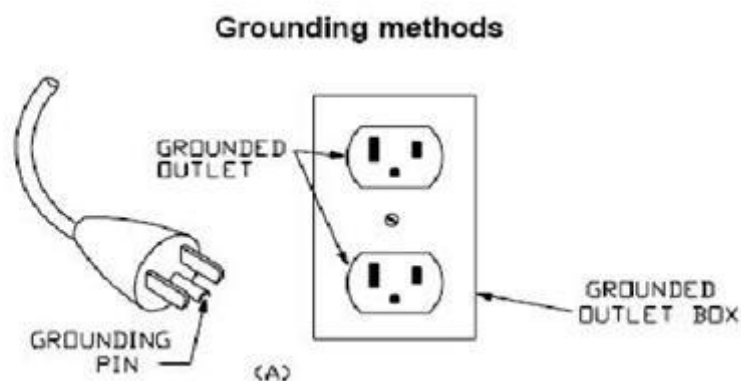

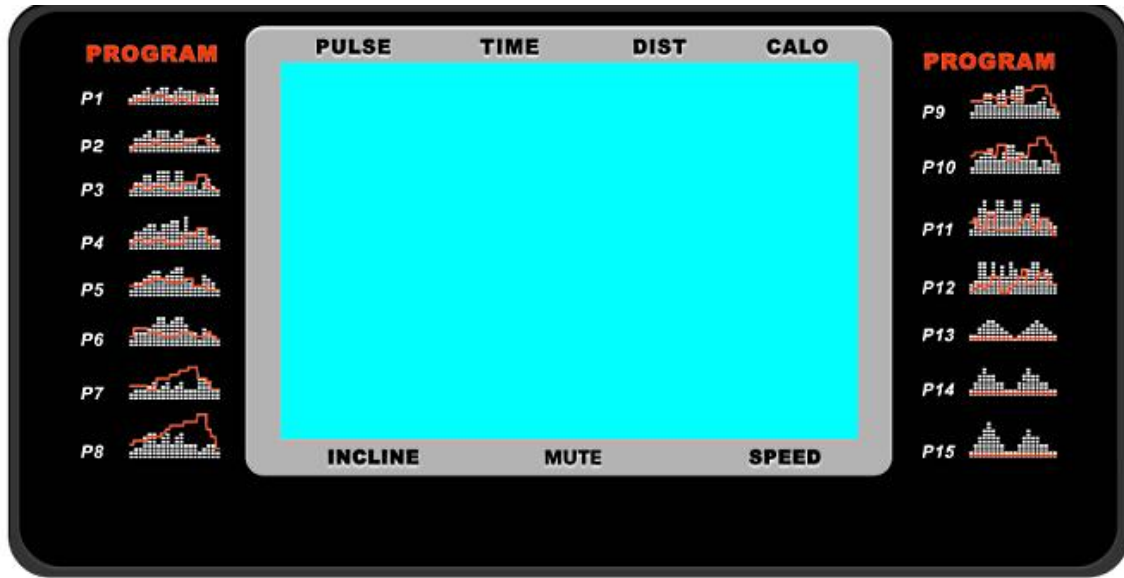

8. OPERATION GUIDE



1. Window display, as shown on console:

PULSE:	Heart rate
TIME:	Shows time
DISTANCE:	Shows distance
CAL:	Shows calories
LAPS:	Shows laps
KM, M:	Shows speed, Matrix show speed and incline under program mode 20sections
INCLINE:	Shows incline gradient
SPEED:	Shows speed

2. Button functions:

'PROG'	Button to choose program. Cycles through: Manual, P1-P99
'MODE'	Button for countdown. Cycles through: Manual, time countdown, distance countdown, calorie countdown
'START'	Button to start. By pressing this button the treadmill will start with the lowest speed or speed by default program after a countdown of 3 seconds
'STOP'	Button to stop. By pressing this button during operation the treadmill will slow down slowly until a stop
'SPEED'	Speed +/- adjustment. Increases or decreases speed during operation. Sets parameter when stopped
'SPEED (5 8 12 15) '	Instant speed adjustment buttons
'INCLINE '	Incline adjustment up and down. Adjust the incline gradient during exercising. Sets parameter when stopped
'INCLINE (3 6 9 12) '	Instant incline adjustment buttons
	Amplifier mute \ play button
	Fan function switch button. Turns fan on/off
Left handlebar keys	Incline adjustment buttons
Right handlebar keys	Speed adjustment buttons

3. General operational procedure (manual)

Turn the power on, attach safety key, press PROGRAM button to cycle choosing a set program (P1-99), press start key, LCD will display a 3 second countdown then the machine will run at the lowest speed, toggle speed and incline using buttons on the console or handlebars. Upon workout completion, press the STOP key.

4. Countdown Mode:

Press MODE button to cycle through, time count down, distance count down, calories count down. Press SPEED buttons to adjust the data requested. Then press START button, front window display: 3—2—1, then start treadmill, the machine will run at 1 km/h, press SPEED and INCLINE buttons to adjust speed and gradient. When the window data counts down to 0 the machine will stop smoothly. You can press STOP or take off the safety key to stop running at any time.

5. Preset installed programs and “USER” programs:

Press “PROGRAM” button and the SPEED window will display P1-P99 to choose the program you like. The TIME window will then flash, press SPEED arrows to set desired exercise time.

The preset installed programs are divided into 20 sections with the time for each section is 1/20th of the total exercise time. Press the START button and the treadmill will start with the first section’s speed and equivalent gradient after a 3 second countdown. After completing the first section the treadmill will enter the next section automatically. Speed and incline will also be automatically adjusted to this section’s parameter. After all sections are complete the program will end and the treadmill will stop smoothly.

Press SPEED and INCLINE arrow buttons to adjust speed and incline gradient during the workout. When the program enters the next section it will adjust to the default program automatically. You can also press STOP or take off the safety key to stop running.

The Preset data is in the table below. After cycling through the programs using PROG and reaching P99, continue pressing PROG and the user defined programs: U1, U2, U3 will appear sequentially.

U1 is divided into 20 sections. Speed and incline for each segment are to be entered by the user. After setting all 20 segments, the time window will flash. Then you can set the desired time. Press start, then begin enter into user program. User programs can be saved even when powered off.

	Initial	Set initial value	Set range	Show range
TIME (Min.: Sec.)	0:00	30:00	10:00-99:00	0:00—99:59
SPEED(KM/H)	0.0	N/A	N/A	1.0—22.0
DISTANCE(KM)	0.00	1.0	0.5—99.00	0.00—99.99
PULSE (Times/Min.)	P	N/A	N/A	40—200
CALORIES(Kcal)	0	50	10—999	0—999
INCLINE	N	0	0-20	0-20

6. Body fat test:

Press the MODE button to enter the body fat test program. Press + or – to select sex, press MODE to confirm. Enter age setting, press + or – to adjust age, press MODE to confirm. Enter height setting, press + or – to adjust height, press MODE to confirm. Enter weight setting, press + or – to adjust weight, press MODE to confirm. Now parameter window will display "-- -- --", hold the pulse sensors for five seconds and it will display your body mass index (BMI).

Body fat index parameter table:

Parameter class	Default	Setting range	Remark
Sex	0 (Male)	0—1	0=Male 1= Female
Age	25 years	10—99 years	
Height	170 CM	100—240 CM	
Weight	70KG	20—160KG	

7. Heart rate test:

Hold the hand pulse sensors and the window will show your heartbeat after 5 seconds. In order to achieve the most accurate heart rate reading, please perform this test when the machine stopped and holding the sensors for no less than 30 seconds. This data is only for reference, and not to be used for medical purposes.

8. Safety function:

If the safety key is pulled off the window will display "SAFEKEY", the treadmill will emit a beeping sound, at this time machine cannot operate. After replacing the safety key the LCD window show the weight set up by last time, equipment reset, wait for enter command.

9. Sleep function:

When treadmill stopped, it will enter sleep function if no commands are entered within 10 minutes. Press the power key to wake the console and resume operation.

10. Program List:

时间段		把设置的时间/20个时间段= 每时间段的运行时间																			
程式		1	2	3	4	5	6	7	8	9	10	11	12	13	14	15	16	17	18	19	20
P1	SPEED	1	1	2	2	2	3	3	2	2	1	2	2	2	1	1	3	3	2	2	2
	INCL	0	0	0	0	0	0	0	0	0	0	0	0	0	0	0	0	0	0	0	0
P2	SPEED	1	2	2	2	2	3	3	2	2	2	2	2	3	3	3	4	4	3	2	2
	INCL	0	0	0	0	0	0	0	0	0	0	0	0	0	0	0	0	0	0	0	0
P3	SPEED	2	3	3	2	2	3	3	3	2	2	2	2	4	4	4	6	6	3	2	2
	INCL	0	0	0	0	0	0	0	0	0	0	0	0	0	0	0	0	0	0	0	0
P4	SPEED	2	3	3	2	2	3	3	3	2	2	2	2	4	4	4	6	6	3	2	2
	INCL	0	0	0	0	0	0	0	0	0	0	0	0	0	0	0	0	0	0	0	0
P5	SPEED	3	3	3	4	4	5	5	5	4	4	4	4	5	5	3	3	3	2	2	2
	INCL	0	0	0	0	0	0	0	0	0	0	0	0	0	0	0	0	0	0	0	0
P6	SPEED	3	5	5	5	4	4	4	3	3	3	3	4	4	4	3	3	3	4	3	2
	INCL	0	0	0	0	0	0	0	0	0	0	0	0	0	0	0	0	0	0	0	0
P7	SPEED	4	4	4	4	3	3	6	6	6	7	7	8	8	9	9	6	6	5	3	3
	INCL	0	0	0	0	0	0	0	0	0	0	0	0	0	0	0	0	0	0	0	0
P8	SPEED	4	5	5	5	6	6	6	7	8	9	9	9	10	10	10	12	12	8	6	3
	INCL	0	0	0	0	0	0	0	0	0	0	0	0	0	0	0	0	0	0	0	0
P9	SPEED	5	5	5	6	6	6	4	4	6	6	5	5	8	8	9	9	9	7	4	2
	INCL	0	0	0	0	0	0	0	0	0	0	0	0	0	0	0	0	0	0	0	0
P10	SPEED	5	6	6	6	7	5	8	8	4	4	4	5	5	8	8	10	10	8	6	3
	INCL	0	0	0	0	0	0	0	0	0	0	0	0	0	0	0	0	0	0	0	0
P11	SPEED	4	5	3	2	6	6	2	2	2	2	2	4	5	6	3	2	5	5	2	1
	INCL	0	0	0	0	0	0	0	0	0	0	0	0	0	0	0	0	0	0	0	0
P12	SPEED	1	2	3	2	3	5	5	5	5	2	3	5	7	3	3	5	6	5	3	3
	INCL	0	0	0	0	0	0	0	0	0	0	0	0	0	0	0	0	0	0	0	0
P13	SPEED	1	1	1	1	1	1	1	1	1	1	1	1	1	1	1	1	1	1	1	1
	INCL	0	0	0	0	0	0	0	0	0	0	0	0	0	0	0	0	0	0	0	0
P14	SPEED	1	1	1	1	1	1	1	1	1	1	1	1	1	1	1	1	1	1	1	1
	INCL	0	0	0	0	0	0	0	0	0	0	0	0	0	0	0	0	0	0	0	0
P15	SPEED	1	1	1	1	1	1	1	1	1	1	1	1	1	1	1	1	1	1	1	1
	INCL	0	0	0	0	0	0	0	0	0	0	0	0	0	0	0	0	0	0	0	0
P16	SPEED	1	1	1	1	1	1	1	1	1	1	1	1	1	1	1	1	1	1	1	1
	INCL	0	0	0	0	0	0	0	0	0	0	0	0	0	0	0	0	0	0	0	0
P17	SPEED	1	1	1	1	1	1	1	1	1	1	1	1	1	1	1	1	1	1	1	1
	INCL	0	0	0	0	0	0	0	0	0	0	0	0	0	0	0	0	0	0	0	0
P18	SPEED	1	1	1	1	1	1	1	1	1	1	1	1	1	1	1	1	1	1	1	1
	INCL	0	0	0	0	0	0	0	0	0	0	0	0	0	0	0	0	0	0	0	0
P19	SPEED	1	1	1	1	1	1	1	1	1	1	1	1	1	1	1	1	1	1	1	1
	INCL	0	0	0	0	0	0	0	0	0	0	0	0	0	0	0	0	0	0	0	0

P20	SPEED	1	1	1	1	1	1	1	1	1	1	1	1	1	1	1	1	1	1	1	
	INCL	0	0	0	0	0	0	0	0	0	0	0	0	0	0	0	0	0	0	0	
P21	SPEED	1	1	1	1	1	1	1	1	1	1	1	1	1	1	1	1	1	1	1	
	INCL	0	0	0	0	0	0	0	0	0	0	0	0	0	0	0	0	0	0	0	
P22	SPEED	1	1	1	1	1	1	1	1	1	1	1	1	1	1	1	1	1	1	1	
	INCL	0	0	0	0	0	0	0	0	0	0	0	0	0	0	0	0	0	0	0	
P23	SPEED	1	1	1	1	1	1	1	1	1	1	1	1	1	1	1	1	1	1	1	
	INCL	0	0	0	0	0	0	0	0	0	0	0	0	0	0	0	0	0	0	0	
P24	SPEED	1	1	1	1	1	1	1	1	1	1	1	1	1	1	1	1	1	1	1	
	INCL	0	0	0	0	0	0	0	0	0	0	0	0	0	0	0	0	0	0	0	
P25	SPEED	2	6	6	8	10	8	6	6	2	2	2	6	6	8	10	8	6	6	2	2
	INCL	0	0	0	0	0	0	0	0	0	0	0	0	0	0	0	0	0	0	0	0
P26	SPEED	2	3	4	5	2	3	4	5	4	3	2	3	4	5	2	3	4	5	4	3
	INCL	0	0	0	0	0	0	0	0	0	0	0	0	0	0	0	0	0	0	0	0
P27	SPEED	2	4	6	2	4	6	2	4	6	2	2	4	6	2	4	6	2	4	6	2
	INCL	0	0	0	0	0	0	0	0	0	0	0	0	0	0	0	0	0	0	0	0
P28	SPEED	1	3	1	2	1	2	1	1	2	2	1	3	1	2	1	2	1	1	2	1
	INCL	0	0	0	0	0	0	0	0	0	0	0	0	0	0	0	0	0	0	0	0
P29	SPEED	1	2	2	3	4	4	3	2	1	2	1	2	2	3	4	4	3	2	1	1
	INCL	0	0	0	0	0	0	0	0	0	0	0	0	0	0	0	0	0	0	0	0
P30	SPEED	1	4	5	7	9	11	9	7	5	3	1	4	5	7	9	11	9	7	5	3
	INCL	0	0	0	0	0	0	0	0	0	0	0	0	0	0	0	0	0	0	0	0
P31	SPEED	2	5	6	8	10	8	6	6	2	2	2	5	6	8	10	8	6	6	2	2
	INCL	0	0	0	0	0	0	0	0	0	0	0	0	0	0	0	0	0	0	0	0
P32	SPEED	2	4	4	5	2	3	4	5	4	3	2	4	4	5	2	3	4	5	4	3
	INCL	0	0	0	0	0	0	0	0	0	0	0	0	0	0	0	0	0	0	0	0
P33	SPEED	2	3	6	2	4	6	2	4	6	6	6	3	6	2	4	6	2	4	6	2
	INCL	0	0	0	0	0	0	0	0	0	0	0	0	0	0	0	0	0	0	0	0
P34	SPEED	4	5	5	5	6	6	6	7	8	9	9	9	10	10	10	12	12	8	6	3
	INCL	0	0	0	0	0	0	0	0	0	0	0	0	0	0	0	0	0	0	0	0
P35	SPEED	5	5	5	6	6	6	4	4	6	6	5	5	8	8	9	9	9	7	4	2
	INCL	0	0	0	0	0	0	0	0	0	0	0	0	0	0	0	0	0	0	0	0
P36	SPEED	5	6	6	6	7	5	8	8	4	4	4	5	5	8	8	10	10	8	6	3
	INCL	0	0	0	0	0	0	0	0	0	0	0	0	0	0	0	0	0	0	0	0
P37	SPEED	2	6	6	8	10	8	6	6	2	2	2	6	6	8	10	8	6	6	2	2
	INCL	0	0	0	0	0	0	0	0	0	0	0	0	0	0	0	0	0	0	0	0
P38	SPEED	2	3	4	5	2	3	4	5	4	3	2	3	4	5	2	3	4	5	4	3
	INCL	0	0	0	0	0	0	0	0	0	0	0	0	0	0	0	0	0	0	0	0
P39	SPEED	2	4	6	2	4	6	2	4	6	2	2	4	6	2	4	6	2	4	6	2
	INCL	0	0	0	0	0	0	0	0	0	0	0	0	0	0	0	0	0	0	0	0
P40	SPEED	1	3	1	2	1	2	1	1	2	2	1	3	1	2	1	2	1	1	2	1
	INCL	0	0	0	0	0	0	0	0	0	0	0	0	0	0	0	0	0	0	0	0
P41	SPEED	1	2	2	3	4	4	3	2	1	2	1	2	2	3	4	4	3	2	1	1
	INCL	0	0	0	0	0	0	0	0	0	0	0	0	0	0	0	0	0	0	0	0

P42	SPEED	1	4	5	7	9	11	9	7	5	3	1	4	5	7	9	11	9	7	5	3
	INCL	0	0	0	0	0	0	0	0	0	0	0	0	0	0	0	0	0	0	0	0
P43	SPEED	2	5	6	8	10	8	6	6	2	2	2	5	6	8	10	8	6	6	2	2
	INCL	0	0	0	0	0	0	0	0	0	0	0	0	0	0	0	0	0	0	0	0
P44	SPEED	2	4	4	5	2	3	4	5	4	3	2	4	4	5	2	3	4	5	4	3
	INCL	0	0	0	0	0	0	0	0	0	0	0	0	0	0	0	0	0	0	0	0
P45	SPEED	2	3	6	2	4	6	2	4	6	2	2	3	6	2	4	6	2	4	6	2
	INCL	0	0	0	0	0	0	0	0	0	0	0	0	0	0	0	0	0	0	0	0
P46	SPEED	4	5	5	5	6	6	6	7	8	9	9	9	10	10	10	12	12	8	6	3
	INCL	0	0	0	0	0	0	0	0	0	0	0	0	0	0	0	0	0	0	0	0
P47	SPEED	5	5	5	6	6	6	4	4	6	6	5	5	8	8	9	9	9	7	4	2
	INCL	0	0	0	0	0	0	0	0	0	0	0	0	0	0	0	0	0	0	0	0
P48	SPEED	5	6	6	6	7	5	8	8	4	4	4	5	5	8	8	10	10	8	6	3
	INCL	0	0	0	0	0	0	0	0	0	0	0	0	0	0	0	0	0	0	0	0
P49	SPEED	2	3	3	4	5	6	4	5	5	3	4	5	4	4	4	2	3	3	5	3
	INCL	0	0	0	0	0	0	0	0	0	0	0	0	0	0	0	0	0	0	0	0
P50	SPEED	2	4	4	5	6	4	6	6	6	4	5	6	4	4	4	2	2	5	4	2
	INCL	0	0	0	0	0	0	0	0	0	0	0	0	0	0	0	0	0	0	0	0
P51	SPEED	1	1	2	2	2	3	3	2	2	1	2	2	2	1	1	3	3	2	2	2
	INCL	2	4	4	6	6	4	7	7	7	4	7	7	4	4	4	2	4	5	3	2
P52	SPEED	1	2	2	2	2	3	3	2	2	2	2	2	3	3	3	4	4	3	2	2
	INCL	3	5	5	6	7	7	5	7	7	8	8	5	9	5	5	6	6	4	4	3
P53	SPEED	2	3	3	2	2	3	3	3	2	2	2	2	4	4	4	6	6	3	2	2
	INCL	2	4	4	5	6	7	7	5	6	7	8	8	5	4	3	3	6	5	4	2
P54	SPEED	2	3	3	2	2	3	3	3	2	2	2	2	4	4	4	6	6	3	2	2
	INCL	2	4	4	4	5	6	8	8	6	7	8	8	6	4	4	2	5	4	3	2
P55	SPEED	3	3	3	4	4	5	5	5	4	4	4	4	5	5	3	3	3	2	2	2
	INCL	2	3	3	3	4	5	3	4	5	3	4	5	3	3	3	6	6	5	3	3
P56	SPEED	3	5	5	5	4	4	4	3	3	3	3	4	4	4	3	3	3	4	3	2
	INCL	2	3	3	6	7	7	4	6	7	4	6	7	4	4	4	2	3	4	4	2
P57	SPEED	4	4	4	4	3	3	6	6	6	7	7	8	8	9	9	6	6	5	3	3
	INCL	2	4	4	7	7	4	7	8	4	8	9	9	4	4	4	5	6	3	3	2
P58	SPEED	4	5	5	5	6	6	6	7	8	9	9	9	10	10	10	12	12	8	6	3
	INCL	2	4	5	6	7	5	4	6	8	8	6	6	5	4	4	2	4	4	3	3
P59	SPEED	5	5	5	6	6	6	4	4	6	6	5	5	8	8	9	9	9	7	4	2
	INCL	2	5	8	10	7	7	10	10	7	7	10	10	6	6	9	9	5	5	4	3
P60	SPEED	5	6	6	6	7	5	8	8	4	4	4	5	5	8	8	10	10	8	6	3
	INCL	3	4	9	9	5	9	5	8	5	9	7	5	5	7	9	9	5	7	6	3
P61	SPEED	4	5	3	2	6	6	2	2	2	2	2	4	5	6	3	2	5	5	2	1
	INCL	2	3	4	5	6	5	4	3	2	1	2	3	4	5	6	5	4	3	2	1
P62	SPEED	1	2	3	2	3	5	5	5	5	2	3	5	7	3	3	5	6	5	3	3
	INCL	2	4	6	8	6	6	4	4	2	2	2	4	6	8	6	6	4	4	2	2
P63	SPEED	1	1	1	1	1	1	1	1	1	1	1	1	1	1	1	1	1	1	1	1
	INCL	2	4	6	8	10	8	6	4	2	2	2	4	6	8	10	8	6	4	2	2

P64	SPEED	1	1	1	1	1	1	1	1	1	1	1	1	1	1	1	1	1	1	1	
	INCL	2	2	6	6	8	10	6	6	2	2	2	2	6	6	8	10	6	6	2	2
P65	SPEED	1	1	1	1	1	1	1	1	1	1	1	1	1	1	1	1	1	1	1	
	INCL	2	3	4	5	2	3	4	5	3	2	2	3	4	5	2	3	4	5	3	2
P66	SPEED	1	1	1	1	1	1	1	1	1	1	1	1	1	1	1	1	1	1	1	
	INCL	2	4	6	2	4	6	2	4	6	2	2	4	6	2	4	6	2	4	6	2
P67	SPEED	1	1	1	1	1	1	1	1	1	1	1	1	1	1	1	1	1	1	1	
	INCL	1	3	4	5	6	4	5	3	2	1	1	3	4	5	6	5	4	3	2	1
P68	SPEED	1	1	1	1	1	1	1	1	1	1	1	1	1	1	1	1	1	1	1	
	INCL	1	4	6	8	6	6	4	4	2	2	1	4	6	8	6	6	4	4	2	2
P69	SPEED	1	1	1	1	1	1	1	1	1	1	1	1	1	1	1	1	1	1	1	
	INCL	1	4	6	8	10	8	6	4	2	2	10	4	6	8	10	8	6	4	2	2
P70	SPEED	1	1	1	1	1	1	1	1	1	1	1	1	1	1	1	1	1	1	1	
	INCL	1	2	6	6	8	10	6	6	2	2	1	2	6	6	8	10	6	6	2	2
P71	SPEED	1	1	1	1	1	1	1	1	1	1	1	1	1	1	1	1	1	1	1	
	INCL	1	3	4	5	2	3	4	5	3	2	1	3	4	5	2	3	4	5	3	2
P72	SPEED	1	1	1	1	1	1	1	1	1	1	1	1	1	1	1	1	1	1	1	
	INCL	1	4	6	2	4	6	2	4	6	2	1	4	6	2	4	6	2	4	6	2
P73	SPEED	1	1	1	1	1	1	1	1	1	1	1	1	1	1	1	1	1	1	1	
	INCL	2	3	4	5	6	5	4	3	2	1	2	3	4	5	6	5	4	3	2	1
P74	SPEED	1	1	1	1	1	1	1	1	1	1	1	1	1	1	1	1	1	1	1	
	INCL	2	4	6	8	6	6	4	4	2	2	2	4	6	8	6	6	4	4	2	2
P75	SPEED	2	6	6	8	10	8	6	6	2	2	2	6	6	8	10	8	6	6	2	2
	INCL	2	4	6	8	10	8	6	4	2	2	2	4	6	8	10	8	6	4	2	2
P76	SPEED	2	3	4	5	2	3	4	5	4	3	2	3	4	5	2	3	4	5	4	3
	INCL	2	2	6	6	8	10	6	6	2	2	2	2	6	6	8	10	6	6	2	2
P77	SPEED	2	4	6	2	4	6	2	4	6	2	2	4	6	2	4	6	2	4	6	2
	INCL	2	3	4	5	2	3	4	5	3	2	2	3	4	5	2	3	4	5	3	2
P78	SPEED	1	3	1	2	1	2	1	1	2	2	1	3	1	2	1	2	1	1	2	1
	INCL	2	4	6	2	4	6	2	4	6	2	2	4	6	2	4	6	2	4	6	2
P79	SPEED	1	2	2	3	4	4	3	2	1	2	1	2	2	3	4	4	3	2	1	1
	INCL	1	3	4	5	6	5	4	3	2	1	1	3	4	5	6	5	4	3	2	1
P80	SPEED	1	4	5	7	9	11	9	7	5	3	1	4	5	7	9	11	9	7	5	3
	INCL	1	4	6	8	6	6	4	4	2	2	1	4	6	8	6	6	4	4	2	2
P81	SPEED	2	5	6	8	10	8	6	6	2	2	2	5	6	8	10	8	6	6	2	2
	INCL	1	4	6	8	10	8	6	4	2	2	1	4	6	8	10	8	6	4	2	2
P82	SPEED	2	4	4	5	2	3	4	5	4	3	2	4	4	5	2	3	4	5	4	3
	INCL	2	3	3	6	7	7	4	6	7	4	6	7	4	4	4	2	3	4	4	2
P83	SPEED	2	3	6	2	4	6	2	4	6	6	6	3	6	2	4	6	2	4	6	2
	INCL	2	4	4	7	7	4	7	8	4	8	9	9	4	4	4	5	6	3	3	2
P84	SPEED	4	5	5	5	6	6	6	7	8	9	9	9	10	10	10	12	12	8	6	3
	INCL	2	4	5	6	7	5	4	6	8	8	6	6	5	4	4	2	4	4	3	3
P85	SPEED	5	5	5	6	6	6	4	4	6	6	5	5	8	8	9	9	9	7	4	2
	INCL	2	3	4	5	6	5	4	3	2	1	2	3	4	5	6	5	4	3	2	1

P86	SPEED	5	6	6	6	7	5	8	8	4	4	4	5	5	8	8	10	10	8	6	3
	INCL	2	4	6	8	6	6	4	4	2	2	2	4	6	8	6	6	4	4	2	2
P87	SPEED	2	6	6	8	10	8	6	6	2	2	2	6	6	8	10	8	6	6	2	2
	INCL	2	4	6	8	10	8	6	4	2	2	2	4	6	8	10	8	6	4	2	2
P88	SPEED	2	3	4	5	2	3	4	5	4	3	2	3	4	5	2	3	4	5	4	3
	INCL	2	2	6	6	8	10	6	6	4	4	4	4	6	6	8	10	6	6	2	2
P89	SPEED	2	4	6	2	4	6	2	4	6	2	2	4	6	2	4	6	2	4	6	2
	INCL	2	3	4	5	2	3	4	5	3	2	2	3	4	5	2	3	4	5	3	2
P90	SPEED	1	3	1	2	1	2	1	1	2	2	1	3	1	2	1	2	1	1	2	1
	INCL	2	4	6	2	4	6	2	4	6	2	2	4	6	2	4	6	2	4	6	2
P91	SPEED	1	2	2	3	4	4	3	2	1	2	1	2	2	3	4	4	3	2	1	1
	INCL	1	3	4	5	6	5	4	3	2	1	1	3	4	5	6	5	4	3	2	1
P92	SPEED	1	4	5	7	9	11	9	7	5	3	1	4	5	7	9	11	9	7	5	3
	INCL	1	4	6	8	6	6	4	4	2	2	1	4	6	8	6	6	4	4	2	2
P93	SPEED	2	5	6	8	10	8	6	6	2	2	2	5	6	8	10	8	6	6	2	2
	INCL	1	4	6	8	10	8	6	4	2	2	1	4	6	8	10	8	6	4	2	2
P94	SPEED	2	4	4	5	2	3	4	5	4	3	2	4	4	5	2	3	4	5	4	3
	INCL	2	3	3	6	7	7	4	6	7	4	6	7	4	4	4	2	3	4	4	2
P95	SPEED	2	3	6	2	4	6	2	4	6	2	2	3	6	2	4	6	2	4	6	2
	INCL	2	4	4	7	7	4	7	8	4	8	9	9	4	4	4	5	6	3	3	2
P96	SPEED	4	5	5	5	6	6	6	7	8	9	9	9	10	10	10	12	12	8	6	3
	INCL	2	4	5	6	7	5	4	6	8	8	6	6	5	4	4	2	4	4	3	3
P97	SPEED	5	5	5	6	6	6	4	4	6	6	5	5	8	8	9	9	9	7	4	2
	INCL	2	4	6	8	10	8	6	4	2	2	2	4	6	8	10	8	6	4	2	2
P98	SPEED	5	6	6	6	7	5	8	8	4	4	4	5	5	8	8	10	10	8	6	3
	INCL	2	4	5	6	7	5	4	6	8	8	6	6	5	4	4	2	4	4	3	3
P99	SPEED	2	3	3	4	5	6	4	5	5	3	4	5	4	4	4	2	3	3	5	3
	INCL	2	3	3	6	7	7	4	6	7	4	6	7	4	4	4	2	3	4	4	2

9. EXERCISE GUIDE

PLEASE NOTE: Before beginning any exercise program, consult your physician. This is important especially if you are over the age of 45 or individuals with pre-existing health problems.

The pulse sensors are not medical devices. Various factors, including the user's movement, may affect the accuracy of heart rate readings. The pulse sensors are intended only as an exercise aid in determining heart rate trends in general.

Exercising is great way to control your weight, improving your fitness and reduce the effect of aging and stress. The key to success is to make exercise a regular and enjoyable part of your everyday life.

The condition of your heart and lungs and how efficient they are in delivering oxygen via your blood to your muscles is an important factor to your fitness. Your muscles use this oxygen to provide enough energy for daily activity. This is called aerobic activity. When you are fit, your heart will not have to work so hard. It will pump a lot fewer times per minute, reducing the wear and tear of your heart.

So as you can see, the fitter you are, the healthier and greater you will feel.

Warm-up

Start each workout with 5 to 10 minutes of stretching and some light exercises. A proper warm-up increases your body temperature, heart rate and circulation in preparation for exercise. Ease into your exercise.

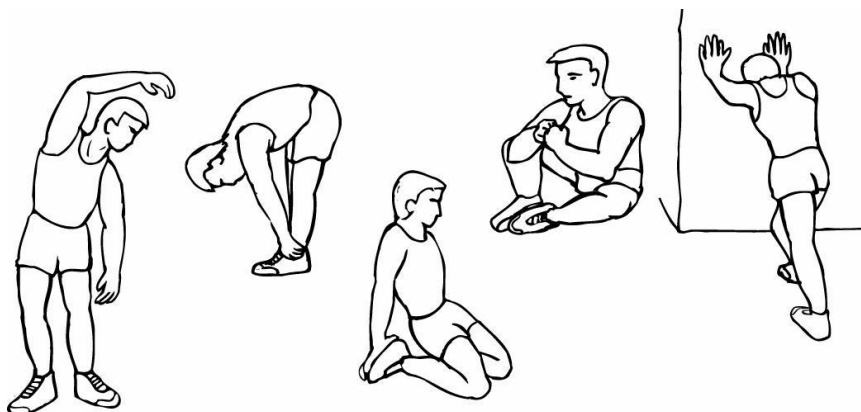

Training Zone Exercise

After warming up, increase the intensity to your desired exercise program. Be sure to maintain your intensity for maximum performance. Breathe regularly and deeply as you exercise-never hold your breath.

Cool Down

Finish each workout with a light jog or walk for at least 1 minute. Then complete 5 to 10 minutes of stretching to cool down. This will increase the flexibility of your muscles and will help prevent post-exercise problems.

Workout Guidelines

TARGET ZONE

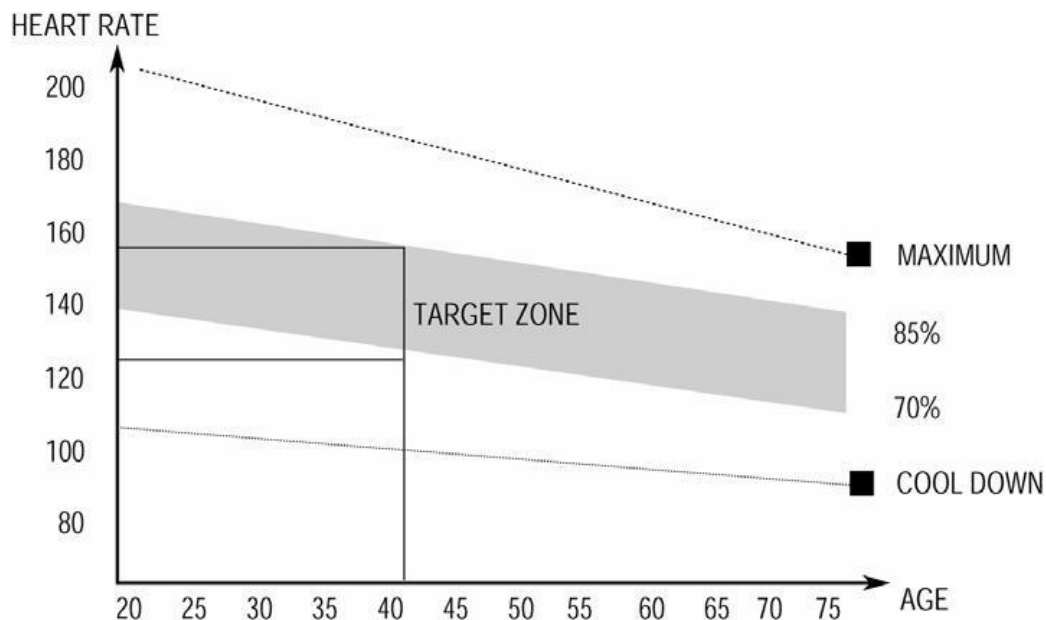

THIS IS HOW YOUR PULSE SHOULD BEHAVE DURING GENERAL FITNESS EXERCISE.

REMEMBER TO WARM UP AND COOL DOWN FOR A FEW MINUTES.

The most important factor here is the amount of effort you put in. The harder and longer you work, the more calories you will burn. Effectively this is the same as if you were training to improve your fitness, the difference is the goal.

10. MAINTENANCE INSTRUCTIONS

Reasonable cleaning/lubricating should be made to extend the life time of this unit. Performance is maximized when the belt and mat are kept as clean as possible.

WARNING: THE MAT/DECK FRICTION MAY PLAY A MAJOR ROLE IN THE FUNCTION AND LIFE OF YOUR TREADMILL AND THAT IS WHY WE RECOMMEND YOU CONSTANTLY LUBRICATE THIS FRICTION POINT TO PROLONG THE USEFUL LIFE OF YOUR TREADMILL. FAILING TO DO THIS MAY VOID YOUR WARRANTY.

WARNING: UNPLUG POWER CORD BEFORE MAINTENANCE

WARNING: STOP TREADMILL BEFORE FOLDING

1. General Cleaning

- Use a soft, damp cloth to wipe the edge of the belt and the area between the belt edge and frame. A mild soap and water solution along with a nylon scrub brush will clean the top of the textured belt. This task should be done once a month. Allow to dry before using.
- On a monthly basis, vacuum underneath your treadmill to prevent dust build up. Once a year, you should remove the black motor shield and vacuum out dirt that may accumulate.

2. General Care

- Check parts for wear before use.
- Pay particular attention to the fixing knobs and make sure they are tight.
- Always replace the mat if worn and any other defective parts.

- If in doubt do not use the treadmill and contact our helpline.

TAKE CARE TO PROTECT CARPETS AND FLOOR in case of leakages. This product is a machine that contains moving parts which have been greased / lubricated and could leak.

3. Belt/Deck/Roller Lubrication

The mat/deck friction may play a major role in the function and life of your treadmill and that is why we recommend you constantly lubricate this friction point to prolong the useful life of your treadmill. Lubrication is provided with this unit. You should apply the enclosed lubrication after approximately the first 50 hours of operation. We recommend lubrication of the deck according to the following timetable:

- Light use (less than 3 hours per week) every 6 months
- Medium use (3-5 hours a week) every 3 months
- Heavy use (more than 5 hours per week) every 6-8 weeks

See below procedures for lubricating:

1. Use a soft, dry cloth to wipe the area between the belt and deck.
2. Spread lubricant onto the inside surface of belt and deck evenly (make sure the machine is turned off and power is disconnected).
3. Periodically lubricate the front and rear rollers to keep them at their peak performance. If the treadmill belt/deck/roller is kept reasonably clean it is possible to expect over 1200 hours before relubricating is necessary.

4. How to check the running mat for proper lubrication:

1. Disconnect the main power supply.
2. Fold the treadmill up into the storage position.
3. Feel the underside surface of the running mat.

If the surface is slick when touched, then no further lubrication is needed.

If the surface is dry to the touch, apply a suitable silicone lubricant.

We recommend that you use a silicone based spray to lubricate your Lifespan treadmill. This can be purchased from your local sports retailer or hardware store.

5. Belt Tension Adjustment

It is very important for joggers and runners in order to provide a smooth, steady running surface. Adjustment must be made from the right and left rear roller in order to adjust tension with the Allen Key provided in the parts package. The adjustment bolt is located at the end of the rails as noted in the diagram below:

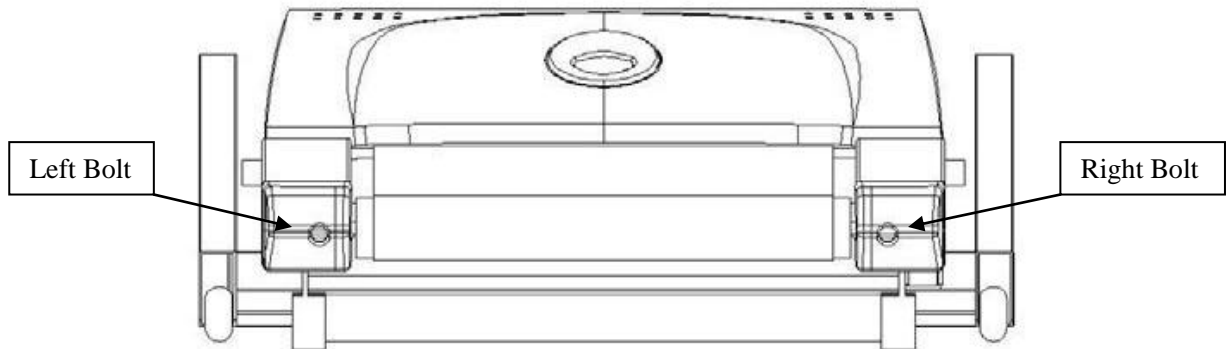

Note: Adjustment is through small hold of end cap.

Tighten the rear roller only enough to prevent slippage at the front roller. Turn both the right and left bolt clockwise one full turn and inspect for proper tension. When an adjustment is made to the belt tension, you must also make a tracking adjustment to compensate for the change in belt tension.

DO NOT OVER TIGHTEN - Over tightening will cause belt damage and premature bearing failure.

This may also cause reduced motor performance and excessive roller wear.

NOTE: When properly tightened, the sides of the belt can be raised approximately 2-3 inches off the board.

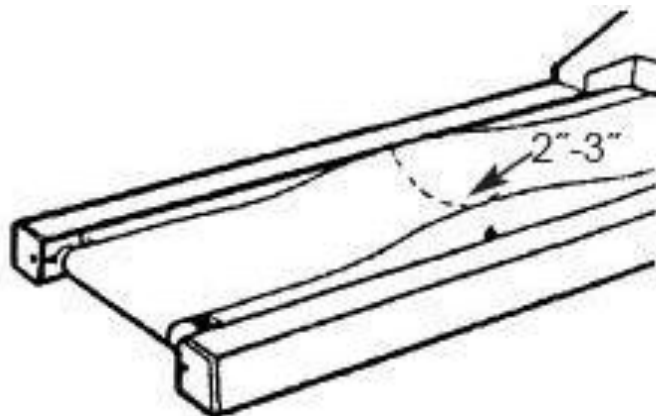

6. Belt Tracking Adjustment:

This treadmill is designed to keep the belt reasonably centred while in use. It is normal for some belts to drift near one side while the belt is running with no one on it. After a few minutes of use, the belt should have a tendency to centre itself. If during use, the belt continues to move toward one side, adjustments are necessary. The procedures are below:

1. Set speed at approximately 3.5km/h.
2. Check the side the belt shifts to.

If the belt shifts to right, tighten the right bolt and loosen the left bolt by using 6mm Allen Key, until the belt is centred itself; If belt shifts to left, tighten the left bolt and loosen the right bolt by using a 6mm Allen Key, until the belt is centred. When adjusting the belt using the 6 mm Allen Key, it is important to adjust the belt in half turn increments. Over adjusting the belt can cause damage to the mat.

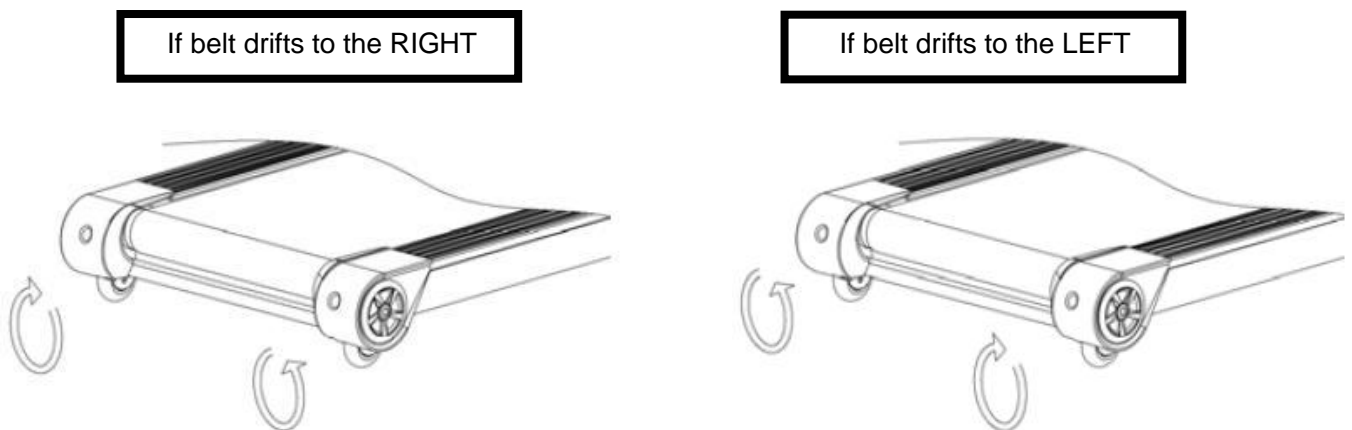

11. EXPLODED DIAGRAM

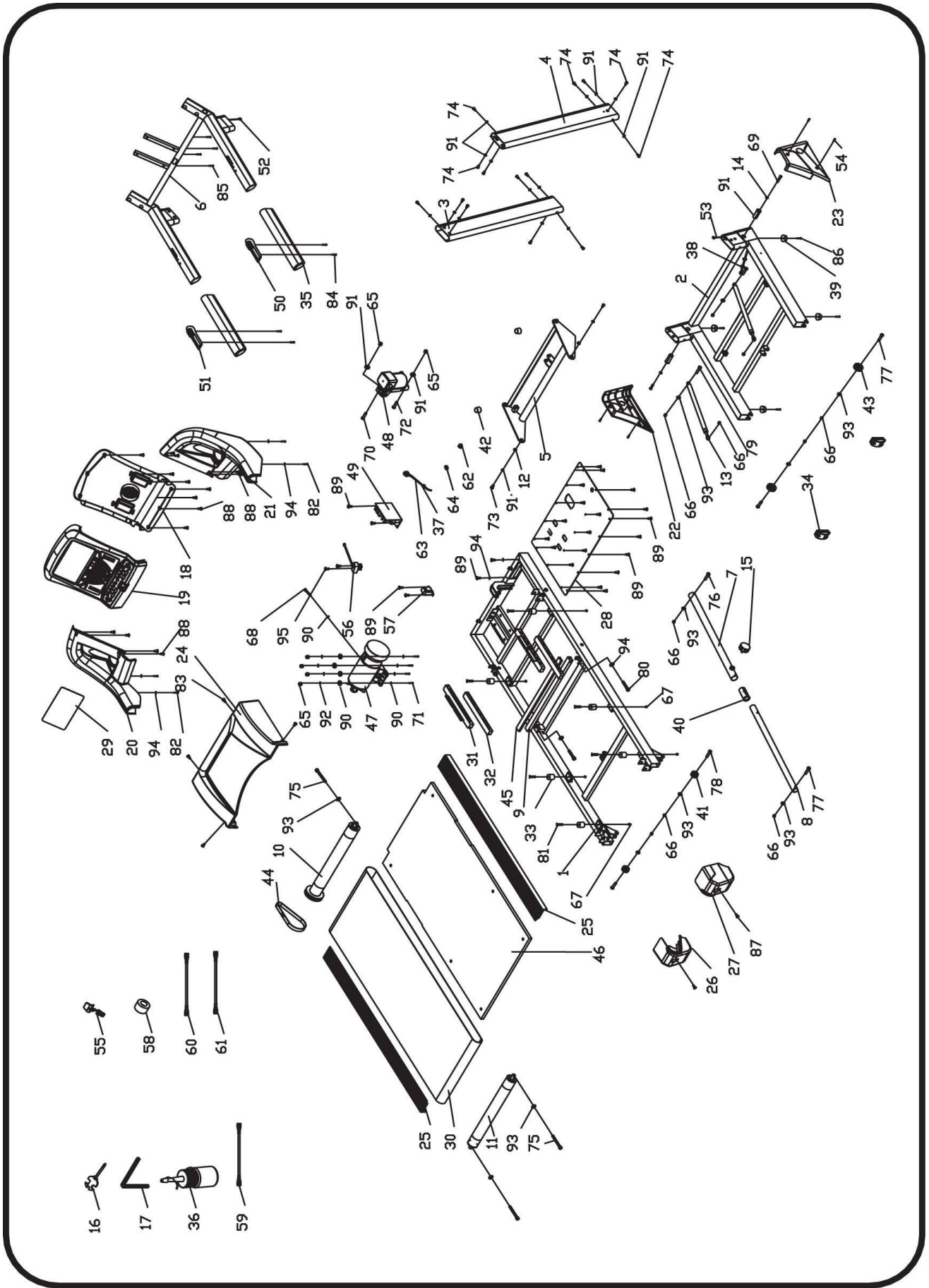

12. PARTS LIST

No.	Description	Spec	Qty.	No.	Description	Spec	Qty.
1	Main frame		1	38	Circle plug B		2
2	Base frame		1	39	Foot pad		4
3	Left upright		1	40	Small tube bushing		1
4	Right upright		1	41	Adjustable wheel		2
5	Incline motor bracket		1	42	Cone-shape cushion pad		2
6	Computer bracket		1	43	Transportation wheel		2
7	Adjustable tube bracket		1	44	Drive belt		1
8	Adjustable bar		1	45	EVA pad		1
9	Stiffened tube for running board		1	46	Running board		1
10	Front roller		1	47	DC motor group		1
11	Rear roller		1	48	Incline motor		1
12	Casing pipe		2	49	Control circuit board		1
13	Cylinder		2	50	Hand pulse with speed button		1
14	Roll casing pipe		2	51	Hand pulse with incline button		1
15	Flexible pin		1	52	Computer up wire		1
16	Allen wrench	S=13, 14、 15	1	53	Computer bottom wire		1
17	6#Allen wrench	6mm	1	54	Screw	ST4.2*19	4
18	Computer bottom cover		1	55	Safety key		1
19	Computer panel		1	56	Light sensor		1
20	Left handrail		1	57	Transformer		1
21	Right handrail		1	58	Magnetic Ring		1
22	Left base cover		1	59	AC Single line		1
23	Right base cover		1	60	Blue single line		1
24	Motor cover		1	61	Brown single line		1
25	Side rail		2	62	Square rocker switch		1
26	Left back end cover		1	63	Standard power wire		1
27	Right back end cover		1	64	Overload protector		1
28	Bottom plate		1	65	I type hexagon nuts	M10	6
29	Acrylic plate		1	66	I type hexagon nuts	M8	10
30	Foot pad for side rail		1	67	I type hexagon nuts	M6	8
31	Long cushion pad 1		2	68	Hexagon bolt	M10*80	1
32	Long cushion pad 2		2	69	Hexagon bolt	M10*60	2
33	Cushion pad		6	70	Hexagon bolt	M10*55	1

No.	Description	Spec	Qty.	No.	Description	Spec	Qty.
34	Roller wheel cover		2	71	Hexagon bolt	M10*45	4
35	Jacket		2	72	Hexagon bolt	M10*42	1
36	Silicone oil		1	73	Hexagon bolt	M10*20	2
37	Power wire buckle		1	74	Hexagon bolt	M10*15	14
75	Hexagon socket cap screw	M8*65	3	86	screws	ST4.8*25	4
76	Hexagon bolt	M8*55	1	87	pan head screws	ST4.8*19	4
77	Hexagon bolt	M8*48	3	88	pan head screws	ST4.2*15	18
78	Hexagon bolt	M8*40	2	89	Screw	ST4.2*12	26
79	Hexagon bolt	M8*25	2	90	Flat washer	10	7
80	pan head screw	M6*45	2	91	Lock washer	10	20
81	Hexagon screw	M6*25	6	92	Spring lock washer	10	4
82	pan head screw	ST4.2*15	4	93	Lock washer	8	13
83	pan head screw	M5*8	4	94	Lock washer	6	9
84	pan head tapping screws	ST4.2*80	4	95	pan head screws	ST2.9*6.5	2
85	pan head tapping screws	ST4.2*30	4				4

13. TROUBLE SHOOTING GUIDE

Computer not functioning after connecting power:

The wire from computer to bottom control board is improperly connected or the transformer is burnt out.

Check each wire from the computer to the control board ensure they are properly connected. If the wire is destroyed, replace it. If the above does not settle the problem, try replacing the transformer.

E01: "Message Failure"

The wires from computer and bottom control board are not properly connected, please check each wire. If the wire was destroyed replace it.

E02: "Burst clash"

Check the power is right, if not, use correct power to test. Check if the bottom control is burnt out, if burnt out replace it and then reconnect the motor wire.

E03: "No sensor signal"

The sensor signal has not been detected within 10 seconds. Check the sensor plug connection or the see if the magnetic sensor is broken or damaged, re-connect the plug well or change the sensor.

E05: "Incline learning defeated"

Check connection of VR wire of incline motor. If improperly connected, reconnect VR and make it firm.

Check to see if AC wire of motor is properly connected, and if the AC wire of the motor is inserted properly with correct sign on control board. Check connection line of motor to see if it is destroyed, exchange it or incline motor. And press "learning" button of bottom control board to relearn upon completion of checks.

Motor not functioning after pressing START button:

Either: the motor wire is broken; the safety pipe is broken or has fallen off; motor wire is not connected well

or IGBT on bottom control board is burnt out. Test the above reasons and change the relevant part.

14. WARRANTY

AUSTRALIAN CONSUMER LAW

Many of our products come with a guarantee or warranty from the manufacturer. In addition, they come with guarantees that cannot be excluded under the Australian Consumer Law. You are entitled to a replacement or refund for a major failure and compensation for any other reasonably foreseeable loss or damage.

You are entitled to have the goods repaired or replaced if the goods fail to be of acceptable quality and the failure does not amount to a major failure. Full details of your consumer rights may be found at www.consumerlaw.gov.au

Please visit our website to view our full warranty terms and conditions:

<http://www.lifespanonline.com.au/Warranty-Policy>